

VI S/STONE/CR

Stone Pendant

by Hangar Design Group

Stone is defined by almost sculptured volumes, where the lightness of mouth blown glass is opposed to the solidity of linear geometries. The pendant is comprised of two distinct pieces: a central bulb holder enclosed in opaque glass for maximum refraction of light; and a transparent diffuser, forming a single composition. The overlapping of the two glass shades produces a new color gradation that can not be achieved otherwise. Available in crystal or smoke finish. Stone was awarded a GOOD DESIGN AWARD by the Chicago Athenaeum Museum of Architecture and Design in 2017.



Designer	Hangar Design Group
Supplier	Vistosi
Country	Italy
SKU	VI S/STONE/CR
Finish	Crystal

Product Dimensions

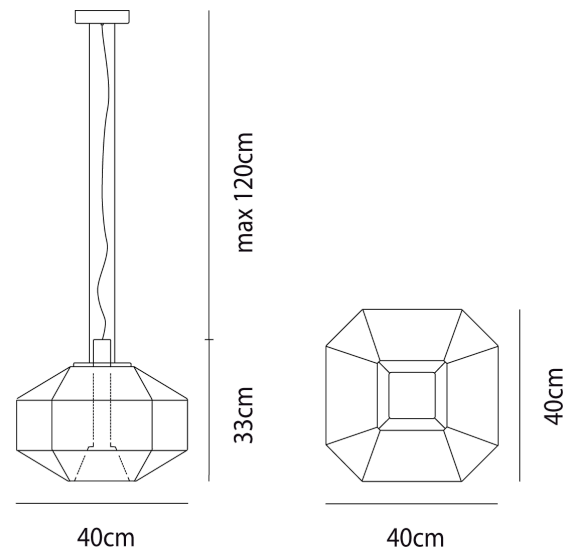

Weight	9kg
Colour Temp	3000K
Dimming	No

Materials	Blown Glass
Output	1850lm

Source	5W LED
IP Rating	IP20